

Stock clearance

Select your **industry** or choose an **anchor lining**

Petrochem

Cement

Steel

Incineration

Power

Shipbuilding

C-serie (Concrete Lining)

D-serie (Dual Lining)

F-serie (Fiber Lining)

Want to see our full stock clearance?

Scroll down!



Index

All anchors are **clickable**

C

CV1
CYA
CVU

D

DRP
DRS

F

FFS
FMS
FTS

I

IPH
ISA
ITS

K

KS

M

MESHs
MPU

R

RIN

S

SHC
SSS
STH

T

TV1

V

V2
V4
VU



C-Serie (Concrete lining)

CV1

CYA

CVU

KS

MESHS

SHC

V2

V4

VU

CV1

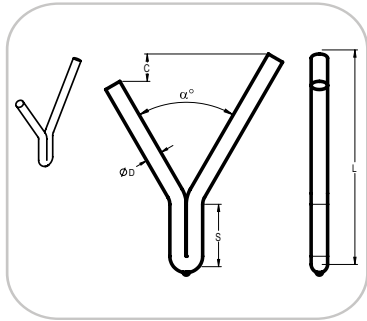

CV1.D (a)-L (c)-alloy	Pcs.	Price
CV1.6(60)-065(00)-304H	13823	€ 0,52

Rapid Arc Welding	✓
Hand Welding	✗

Order

CVU

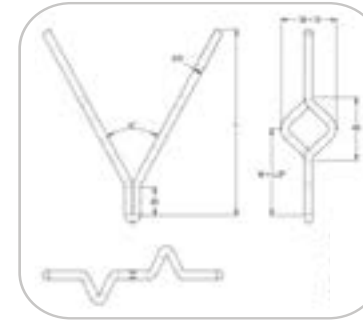

CVU.D(a) - L(c)-alloy		Pcs.	Price
CVU.6(60)152(00)-304	6"	4440	€ 0,82
CVU.6(60)-127(00)-304	5"	350	€ 0,77
CVU.6(60)-102(00)-ST37	4"	10143	€ 0,54
CVU.6(60)102(00)-304	4"	9600	€ 0,69

Rapid Arc Welding	✓
Hand Welding	✗

Order

CYA

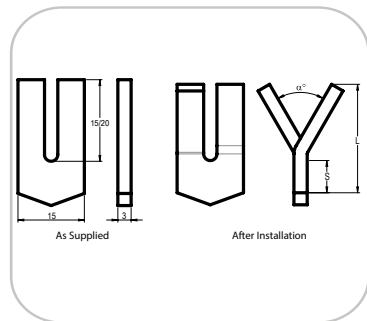

CYA B/T(a) - L(s)-alloy M*	Pcs.	Price
CYA.15/3(60)-030(015)-310- (Can be CYS) - Without alu-spray	3100	€ 0,44
CYA.15/3(60)-030(015)-310- Can be CYS) - With alu-spray	3100	€ 0,52

Rapid Arc Welding	
Hand Welding	

Order

KS

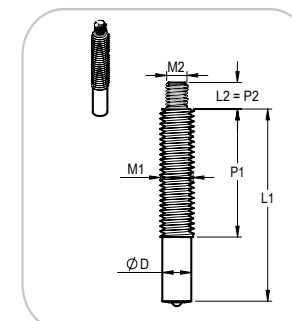

KS.D-L-alloy	Pcs.	Price
KS/BOILER Stud10x25-14742	1159	€ 0,63
Boiler Stud 10x25 -308	26675	€ 0,58
Boiler Stud 10x23-1.4828	8840	€ 0,57
BOILER STUD 10X16-14742	12800	€ 0,48
Sicromal stiften 10x20mm	4682	€ 0,53
Sicromal stiften 10x16mm	2484	€ 0,48
PENØ10X20 mm-310	2050	€ 0,26

Rapid Arc Welding	✓
Hand Welding	✗

Order

C-Serie (Concrete lining)

CV1

CYA

CYU

KS

MESHS

SHC

V2

V4

VU

KS

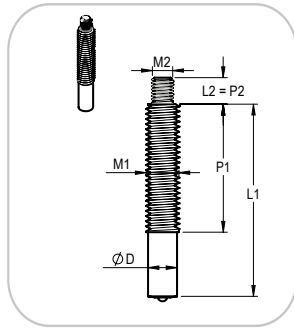

KS.D-L-alloy	Pcs.	Price
KS/BOILER Stud10x25-14742	1159	€ 0,63
Boiler Stud 10x25 -308	26675	€ 0,58
Boiler Stud 10x23-1.4828	8840	€ 0,57
BOILER STUD 10X16-14742	12800	€ 0,48
Sicromal stiften 10x20mm	4682	€ 0,53
Sicromal stiften 10x16mm	2484	€ 0,48
PENØ10X20 mm-310	2050	€ 0,26

Rapid Arc Welding	✓
Hand Welding	✗

Order

SHC

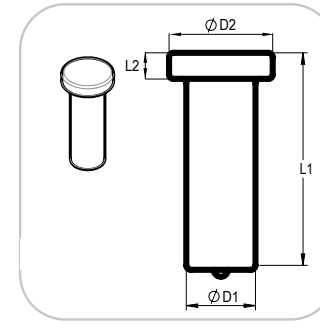

SHC.22-200-ST37	Pcs.	Price
SHC.22-200-ST37	1175	€ 1,45
SHC.19x100-ST37	2055	€ 1,20

Rapid Arc Welding	✓
Hand Welding	✗

Order

MESHS

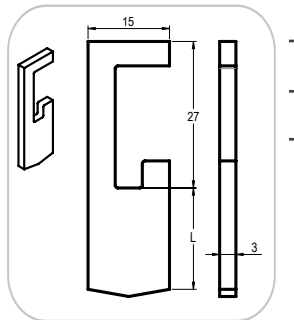

MESHS.B/T -L-alloy	Pcs.	Price
MESHS-15/3-25-310	1819	€ 0,45
MESHS-15/3-025-304	8093	€ 0,42
MESHS.15/3-025-304	514	€ 0,37

Rapid Arc Welding	✓
Hand Welding	✗

Order

V2

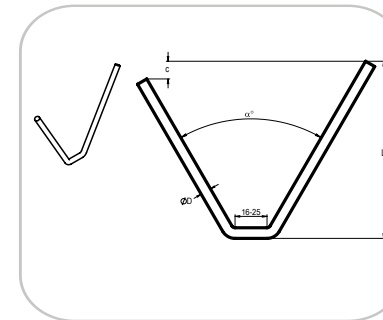

V2.D (α) - L(c)-alloy	Pcs.	Price
V2.08(60)-040(00)-304H	2004	€ 0,33

Rapid Arc Welding	✗
Hand Welding	✓

Order

C-Serie (Concrete lining)

CV1

CVC

CYU

CYA

KS

MESHS

SHC

V2

V4

VU

V4

V4.D (a) - L(c)/e1.e2-alloy	Pcs.	Price
-----------------------------	------	-------

V4.06(60)-150(00)/20-20-304	6900	€ 0,51
-----------------------------	------	--------

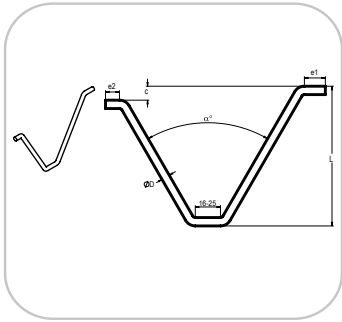

Rapid Arc Welding ✗

Hand Welding ✓

Order

VU

VU.D (a) - L (c) - alloy	Pcs.	Price
--------------------------	------	-------

VU.08(60)-076(00)-304H (3")	1842	€ 0,39
-----------------------------	------	--------

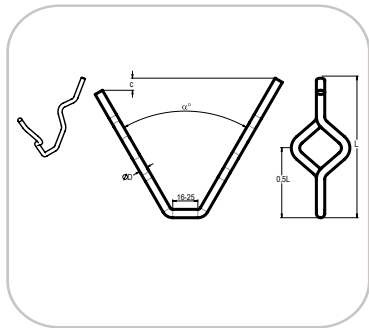

Rapid Arc Welding ✗

Hand Welding ✓

Order

D-Serie (Dual lining)

SSS STH TV1

SSS

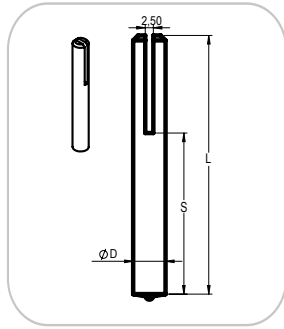

SSS.D-L(S)-alloy	Pcs.	Price
SSS.10-070(035)-310	1075	€ 1,63
SSS.10-053(025)-310	2148	€ 1,33
SSS.10-040(20)-310	4570	€ 1,13
SSS.08-067(33)-310	1978	€ 1,33
SSS.10-015(11,5)-ST37	3051	€ 0,42
SSS.10-015-(11)-600	1009	€ 1,65

Rapid Arc Welding	✓
Hand Welding	✗

Order

STH

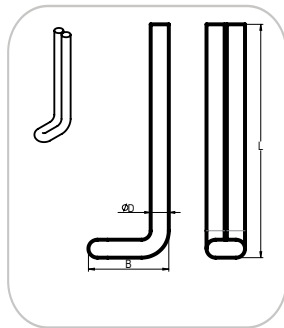

STH.D- L/B-alloy	Pcs.	Price
STH.6-189(025)-304 with 45°cuts	3290	€ 1,28

Rapid Arc Welding	✗
Hand Welding	✓

Order

TV1

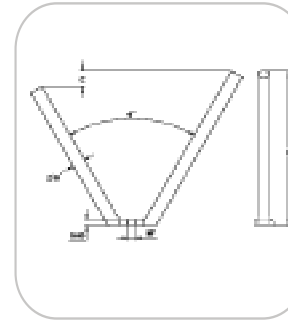

TV1.D(a) - L(c)-alloy M*	Pcs.	Price
TV1.08(60)-032(00)-310 M8	1804	€ 1,05

Rapid Arc Welding	✗
Hand Welding	✓

Order

F-Serie (Fiber lining)

DRP

DRS

FFS

FMS

FTS

IPH

ISA

ITS

MPU

RIN



DRP

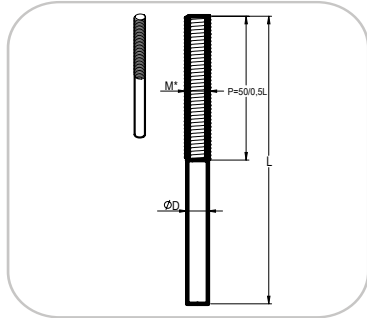

DRP.M* - L-alloy	Pcs.	Price
DRP.10-035-304	3377	€ 0,40
DRP.06-075-304	2175	€ 0,41

Rapid Arc Welding	✓
Hand Welding	✗

Order

FFS

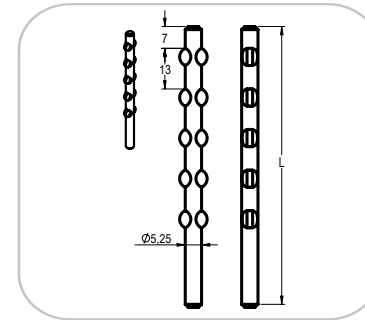

FFS.L-alloy	Pcs.	Price
FFS-100-310	580	€ 0,61
FFS-075-601	2000	€ 0,88
FFS-065-304	1000	€ 0,55
FFS-050-601	2000	€ 0,71
FFS-050-304	1980	€ 0,51

Rapid Arc Welding	✓
Hand Welding	✗

Order

DRS

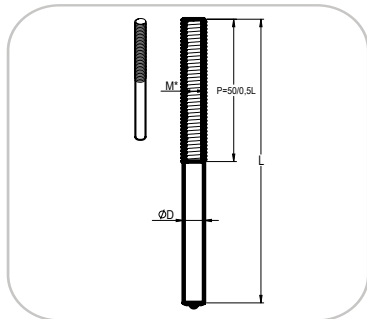

DRS.M - L - alloy	Pcs.	Price
DRS.12-205-310	1607	€ 1,93
DRS.12-150-310	1666	€ 1,58
DRS.12-100-310	702	€ 1,23
DRS.10-025-304	1801	€ 0,74
DRS.08-025-310	2358	€ 0,73
DRS.08-020-310	3838	€ 0,72
DRS.08-018-304	7000	€ 0,67
DRS.08-025-304 RB	8933	€ 0,35
DRS.08-020-304 RB	21705	€ 0,32
DRS.08-020-304 RB	2838	€ 0,32
DRS.08-020-304 RB	1023	€ 0,32
DRS.08-018-304 RB	1586	€ 0,30

Rapid Arc Welding	✓
Hand Welding	✗

Order

FMS

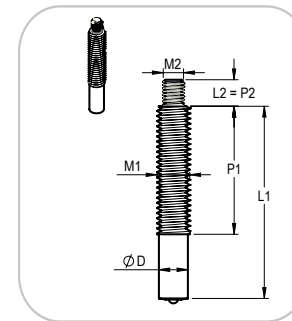

FMS.M1-L1/P1.M2-L2-alloy	Pcs.	Price
FMS.3/8''-051/038-304	4499	€ 1,60
FMS.5/16''-044/044-12-06-304	3089	€ 1,70
FMS.3/8''-051/038-12-08-304	8000	€ 1,75

Rapid Arc Welding	✓
Hand Welding	✗

Order

F-Serie (Fiber lining)

DRP

DRS

FFS

FMS

FTS

IPH

ISA

ITS

MPU

RIN

FTS

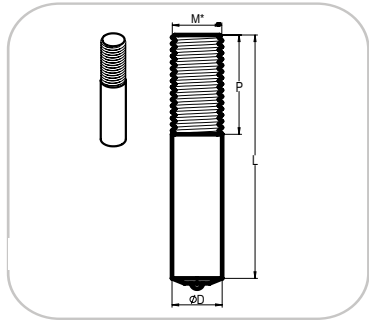

FTS.M-L(P)-alloy	Pcs.	Price
FTS.08-080/15-ST37	3285	€ 0,92

Rapid Arc Welding	✓
Hand Welding	✗

Order

ISA

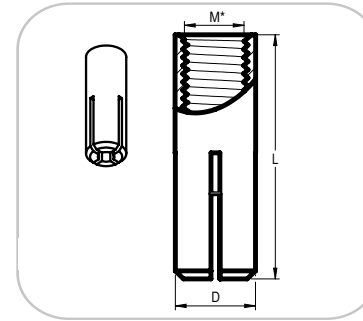

ISA.M-L-alloy	Pcs.	Price
ISA.06-030-316	9044	€ 0,85
ISA.06-030-304	2248	€ 0,75

Rapid Arc Welding	✓
Hand Welding	✗

Order

IPH

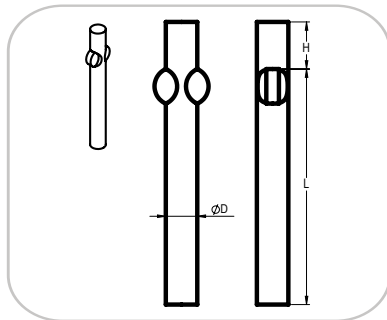

IPH.D-L(H)-alloy	Pcs.	Price
IPH.10-225(16)-308	1623	€ 1,25

Rapid Arc Welding	✗
Hand Welding	✓

Order

ITS

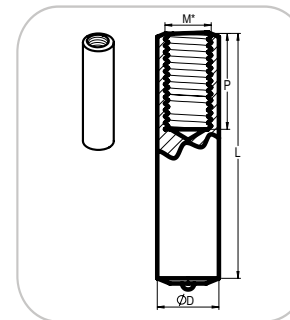

ITS.DxM*-L/P-alloy	Pcs.	Price
ITS.16XM10-025/15-ST37	2681	€ 2,07
ITS.10XM6-025/020-ST37	90090	€ 1,83
ITS.10XM6-025/020-304	56000	€ 1,90

Rapid Arc Welding	✓
Hand Welding	✗

Order

F-Serie (Fiber lining)

DRP

DRS

FFS

FMS

FTS

IPH

ISA

ITS

MPU

RIN

MPU

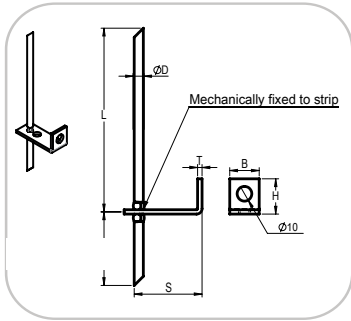

MPU.x.D.S.H(B/T)-L/P-alloy	Pcs.	Price
MPU.2.6.075.25(25/3)-250/050-304	1000	€ 1,25

Rapid Arc Welding ✗

Hand Welding ✓

Order

RIN

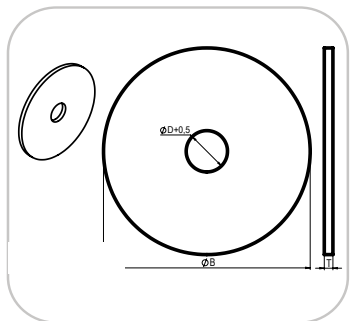

RIN.B - D(T) - alloy	Pcs.	Price
Rin.080-016(2.0)-314	2800	€ 0,80
RIN.060-008(1.5)-321	2975	€ 0,50
RIN.040-014(2.0)-310	4325	€ 0,38
RIN.040-012(2.0)-310	1288	€ 0,37
RIN.038-006(1.5)-310	39840	€ 0,33
RIN.020-010(3.0)-310	780	€ 0,30

Rapid Arc Welding ✗

Hand Welding ✗

Order

Petrochem

CV1

CVC

CYA

CVU

DRP

DRS

FFS

FMS

FTS

ISA

ITS

KS

MESHS

MPU

SSP

SSS

TV1

V2

V4

VU

CV1

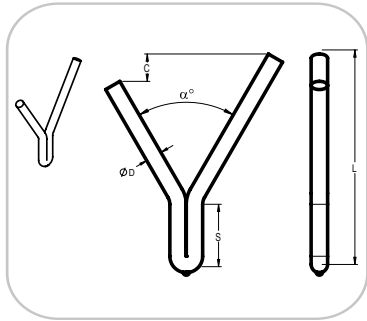

CV1.D (a)-L (c)-alloy	Pcs.	Price
CV1.6(60)-065(00)-304H	13823	€ 0,52
CV1.6(60)-040(00)-310	1439	€ 0,60

Rapid Arc Welding	✓
Hand Welding	✗

Order

CYA

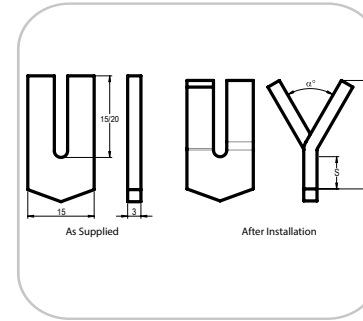

CYA B/T(a) - L(s)-alloy M*	Pcs.	Price
CYA.15/3(60)-030(015)-310- (Can be CYS) - Without alu-spray	3100	€ 0,44
CYA.15/3(60)-030(015)-310- Can be CYS) - With alu-spray	3100	€ 0,52

Rapid Arc Welding	✓
Hand Welding	✗

Order

CVC

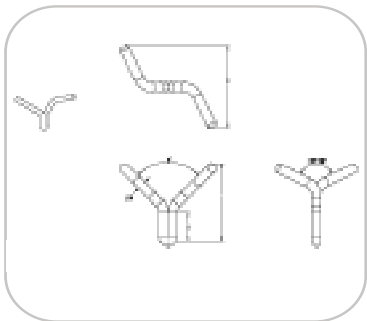

CVC.D(a) - L(s)-alloy M*	Pcs.	Price
CVC.6(90)-048(30)-309L	1678	€ 0,73

Rapid Arc Welding	✓
Hand Welding	✗

Order

CVU

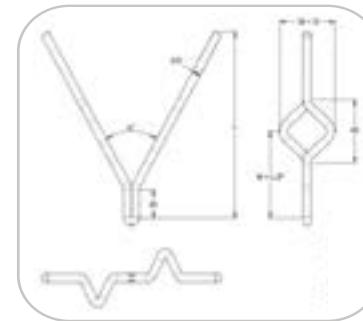

CVU.D(a) - L(c)-alloy	Pcs.	Price
CVU.6(60)152(00)-304 6"	4440	€ 0,82
CVU.6(60)-127(00)-304 5"	3598	€ 0,77
CVU.6(60)-102(00)-ST37 4"	9770	€ 0,54
CVU.6(60)102(00)-304 4"	9600	€ 0,69
CVU.6(60)-075(00)-304	1299	€ 0,72

Rapid Arc Welding	✓
Hand Welding	✗

Order

Petrochem

CV1

CVC

CYA

CVU

DRP

DRS

FFS

FMS

FTS

ISA

ITS

KS

MESH

MPU

SSP

SSS

TV1

V2

V4

VU

DRP

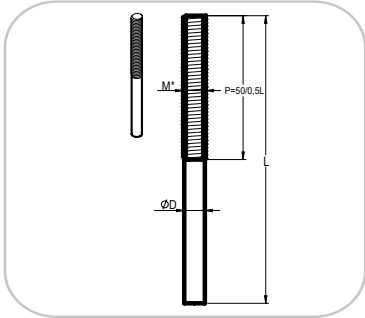

DRP.M* - L-alloy	Pcs.	Price
DRP.10-035-304	3377	€ 0,40
DRP.06-075-304	2395	€ 0,41

Rapid Arc Welding	✓
Hand Welding	✗

Order

FFS

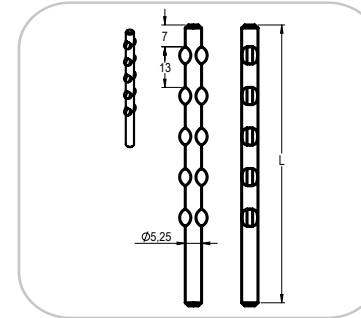

FFS.L-alloy	Pcs.	Price
FFS-100-310	2480	€ 0,61
FFS-075-601	2000	€ 0,88
FFS-065-304	1000	€ 0,55
FFS-050-601	2000	€ 0,71
FFS-050-304	1980	€ 0,51

Rapid Arc Welding	✓
Hand Welding	✗

Order

DRS

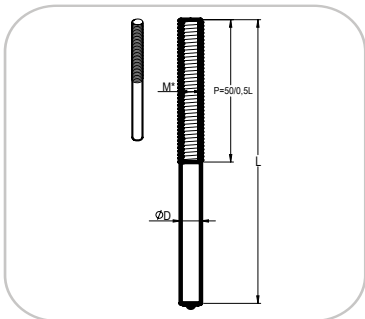

DRS.M - L - alloy	Pcs.	Price
DRS.12-205-310	1942	€ 1,93
DRS.12-150-310	2000	€ 1,58
DRS.12-100-310	1707	€ 1,23
DRS.10-040-304	4769	€ 0,73
DRS.10-025-304	1801	€ 0,74
DRS.08-040-310	2805	€ 0,75
DRS.08-025-310	2458	€ 0,73
DRS.08-020-310	5698	€ 0,72
DRS.08-018-304	7000	€ 0,67
DRS.08-025-304 RB	8933	€ 0,35
DRS.08-020-304 RB	21705	€ 0,32
DRS.08-020-304 RB	2838	€ 0,32
DRS.08-020-304 RB	1023	€ 0,32
DRS.08-018-304 RB	1586	€ 0,30

Rapid Arc Welding	✓
Hand Welding	✗

Order

FMS

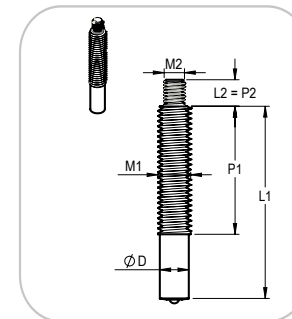

FMS.M1-L1/P1.M2-L2-alloy	Pcs.	Price
FMS.3/8"-051/038-304	4499	€ 1,60
FMS.5/16"-044/044-12-06-304	3494	€ 1,70
FMS.3/8"-051/038-12-08-304	8000	€ 1,75

Rapid Arc Welding	✓
Hand Welding	✗

Order



Petrochem

CV1

CVC

CYA

CVU

DRP

DRS

FFS

FMS

FTS

ISA

ITS**KS**

MESHS

MPU

SSP

SSS

TV1

V2

V4

VU

FTS

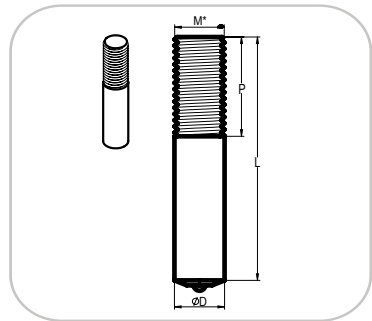

FTS.M-L(P)-alloy	Pcs.	Price
FTS.08-080/15-ST37	3335	€ 0,92

Rapid Arc Welding	✓
Hand Welding	✗

Order

ITS

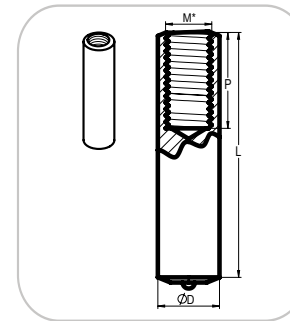

ITS.DxM*-L/P-alloy	Pcs.	Price
ITS.16XM10-025/15-ST37	2681	€ 2,07
ITS.10XM6-025/020-ST37	90100	€ 1,83
ITS.10XM6-025/020-304	56000	€ 1,90

Rapid Arc Welding	✓
Hand Welding	✗

Order

ISA

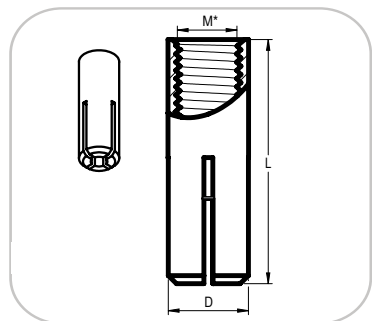

ISA.M-L-alloy	Pcs.	Price
ISA.06-030-316	9847	€ 0,85
ISA.06-030-304	2248	€ 0,75

Rapid Arc Welding	✓
Hand Welding	✗

Order

KS

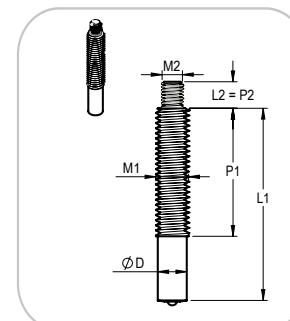

KS.D-L-alloy	Pcs.	Price
KS/BOILER Stud10x25-14742	1159	€ 0,63
Boiler Stud 10x25 -308	26675	€ 0,58
Boiler Stud 10x23-1.4828	8840	€ 0,57
BOILER STUD 10X16-14742	12800	€ 0,48
Sicromal stiften 10x20mm	4682	€ 0,53
Sicromal stiften 10x16mm	2484	€ 0,48
PENØ10X20 mm-310	2050	€ 0,26

Rapid Arc Welding	✓
Hand Welding	✗

Order



Petrochem

CV1

CVC

CYA

CVU

DRP

DRS

FFS

FMS

FTS

ISA

ITS

KS

MESHS

MPU

SSP

SSS

TV1

V2

V4

VU

MESHS

MESHS.B/T -L-alloy	Pcs.	Price
MESHS-15/3-25-310	1819	€ 0,45
MESHS-15/3-025-304 with aluspray	5512	€ 0,42
MESHS.15/3-025-304	3067	€ 0,37

Rapid Arc Welding

Hand Welding

Order

SSP

SSP.D-L(S)-alloy	Pcs.	Price
SSP.10-095-(070)-ST37 open height 90	4800	€ 1,15

Rapid Arc Welding

Hand Welding

Order

MPU

MPU.x.D.S.H(B/T)-L/P-alloy	Pcs.	Price
MPU.2.6.075.25(25/3)-250/050-304	1000	€ 1,25

Rapid Arc Welding

Hand Welding

Order

SSS

SSS.D-L(S)-alloy	Pcs.	Price
SSS.10-070(035)-310	1075	€ 1,63
SSS.10-053(025)-310	2148	€ 1,33
SSS.10-040(20)-310	4570	€ 1,13
SSS.08-067(33)-310	1978	€ 1,33

Rapid Arc Welding

Hand Welding

Order

Petrochem

CV1

CVC

CYA

CVU

DRP

DRS

FFS

FMS

FTS

ISA

ITS

KS

MESHS

MPU

SSP

SSS

TV1

V2

V4

VU

TV1

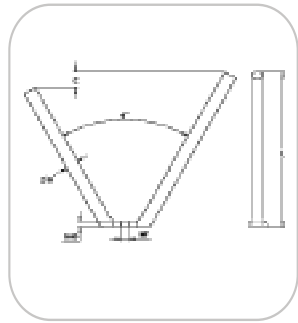

TV1.D(a) - L(c)-alloy M*	Pcs.	Price
TV1.08(60)-032(00)-310 M8	2734	€ 1,05

Rapid Arc Welding ✗

Hand Welding ✓

Order

V4

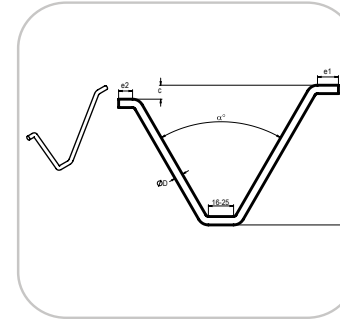

V4.D (a) - L(c)/e1.e2-alloy	Pcs.	Price
V4.06(60)-150(00)/20-20-304	4800	€ 0,51

Rapid Arc Welding ✗

Hand Welding ✓

Order

V2

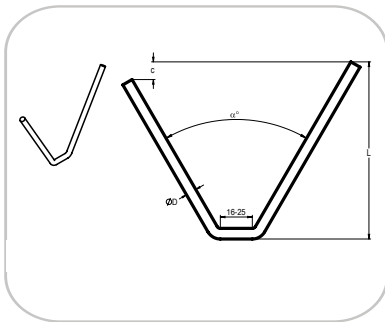

V2.D (a) - L(c)-alloy	Pcs.	Price
V2.08(60)-040(00)-304H	1000	€ 0,33

Rapid Arc Welding ✗

Hand Welding ✓

Order

VU

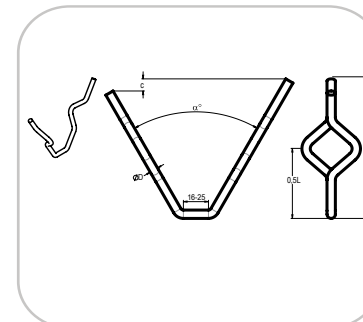

VU.D (a) - L (c) - alloy	Pcs.	Price
VU.06(60)-050(00)-304	2186	€ 0,37

Rapid Arc Welding ✗

Hand Welding ✓

Order



Cement

CV1

CVC

FMS

FTS

ISA

ITS

KS

SSP

SSS

STH

TV1

V2

V4

VU

CV1

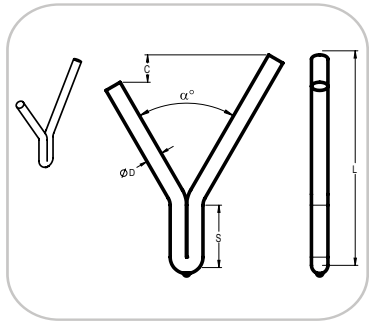

CV1.D (a)-L (c)-alloy	Pcs.	Price
CV1.6(60)-065(00)-304H	13823	€ 0,52
CV1.6(60)-040(00)-310	1439	€ 0,60

Rapid Arc Welding ✓

Hand Welding ✗

Order

FMS

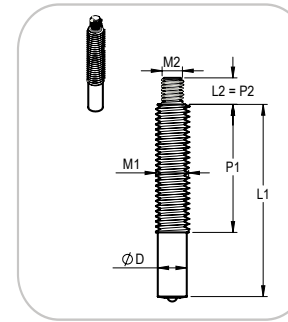

FMS.M1-L1/P1.M2-L2-alloy	Pcs.	Price
FMS.3/8"-051/038-304	4499	€ 1,60
FMS.5/16"-044/044-12-06-304	3494	€ 1,70
FMS.3/8"-051/038-12-08-304	8000	€ 1,75

Rapid Arc Welding ✓

Hand Welding ✗

Order

CVC

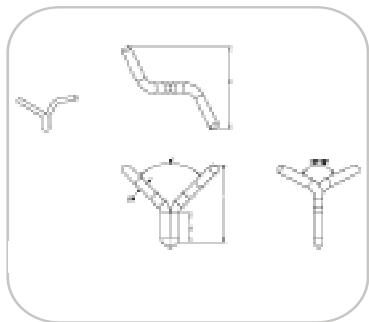

CVC.D(a) - L(s)-alloy M*	Pcs.	Price
CVC.6(90)-048(30)-309L	1678	€ 0,73

Rapid Arc Welding ✓

Hand Welding ✗

Order

FTS

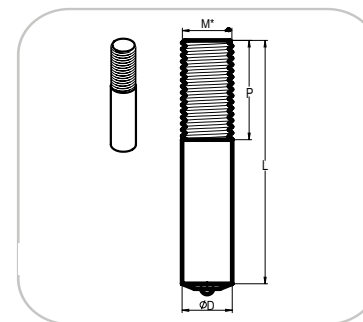

FTS.M-L(P)-alloy	Pcs.	Price
FTS.08-080/15-ST37	3335	€ 0,92

Rapid Arc Welding ✓

Hand Welding ✗

Order



Cement

CV1

CVC

FMS

FTS

ISA

ITS

KS

SSP

SSS

STH

TV1

V2

V4

VU

ISA

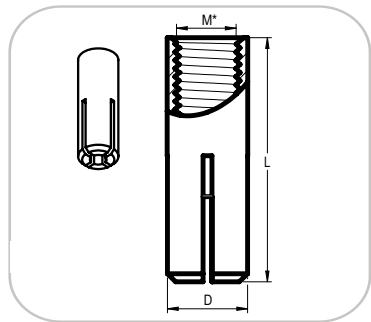

ISA.M-L-alloy	Pcs.	Price
ISA.06-030-316	9847	€ 0,85
ISA.06-030-304	2248	€ 0,75

Rapid Arc Welding ✗

Hand Welding ✓

Order

KS

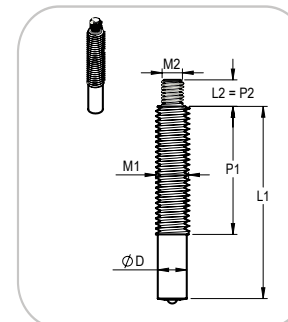

KS.D-L-alloy	Pcs.	Price
KS/BOILER Stud10x25-14742	1159	€ 0,63
Boiler Stud 10x25 -308	26675	€ 0,58
Boiler Stud 10x23-1.4828	8840	€ 0,57
BOILER STUD 10X16-14742	12800	€ 0,48
Sicromal stiften 10x20mm	4682	€ 0,53
Sicromal stiften 10x16mm	2484	€ 0,48
PENØ10X20 mm-310	2050	€ 0,26

Rapid Arc Welding ✓

Hand Welding ✗

Order

ITS

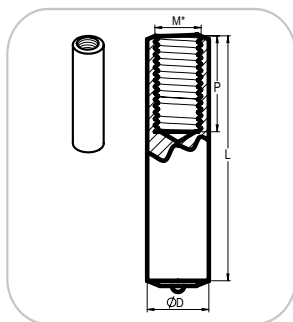

ITS.DxM*-L/P-alloy	Pcs.	Price
ITS.16XM10-025/15-ST37	2681	€ 2,07
ITS.10XM6-025/020-ST37	90100	€ 1,83
ITS.10XM6-025/020-304	56000	€ 1,90

Rapid Arc Welding ✓

Hand Welding ✗

Order

SSP

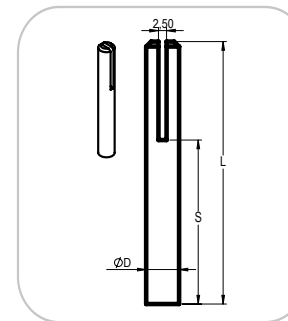

SSP.D-L(S)-alloy	Pcs.	Price
SSP.10-095-(070)-ST37 open height 90	4800	€ 1,15

Rapid Arc Welding ✗

Hand Welding ✓

Order



Cement

CV1

CVC

FMS

FTS

ISA

ITS

KS

SSP

SSS

STH

TV1

V2

V4

VU

SSS

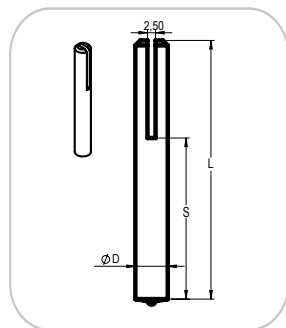

SSS.D-L(S)-alloy	Pcs.	Price
SSS.10-070(035)-310	1075	€ 1,63
SSS.10-053(025)-310	2148	€ 1,33
SSS.10-040(20)-310	4570	€ 1,13
SSS.08-067(33)-310	1978	€ 1,33

Rapid Arc Welding	✓
Hand Welding	✗

Order

TV1

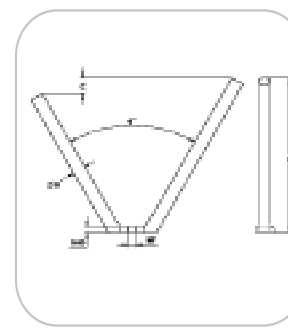

TV1.D(α) - L(c)-alloy M*	Pcs.	Price
TV1.08(60)-032(00)-310 M8	2734	€ 1,05

Rapid Arc Welding	✗
Hand Welding	✓

Order

STH

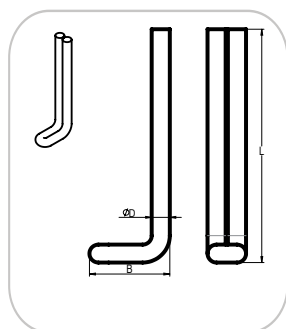

STH.D- L/B-alloy	Pcs.	Price
STH.6-189(025)-304 with 45°cuts	3290	€ 1,28

Rapid Arc Welding	✗
Hand Welding	✓

Order

V2

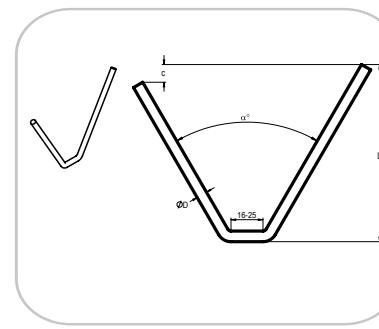

V2.D (α) - L(c)-alloy	Pcs.	Price
V2.08(60)-040(00)-304H	1000	€ 0,33

Rapid Arc Welding	✗
Hand Welding	✓

Order



Cement

CV1

CVC

FMS

FTS

ISA

ITS

KS

SSP

SSS

STH

TV1

V2

V4

VU

V4

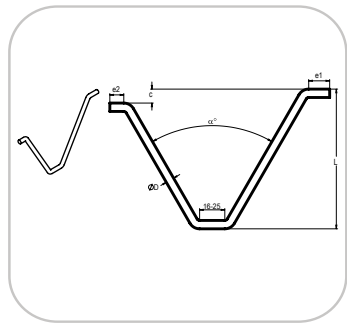

V4.D (a) - L(c)/e1.e2-alloy	Pcs.	Price
V4.06(60)-150(00)/20-20-304	4800	€ 0,51

Rapid Arc Welding	✗
Hand Welding	✓

[Order](#)

VU

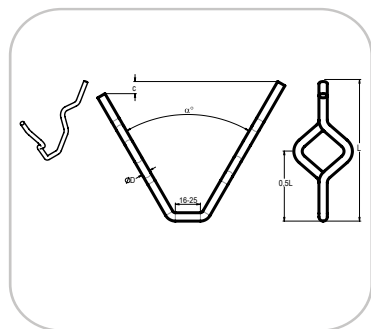

VU.D (a) - L (c) - alloy	Pcs.	Price
VU.06(60)-050(00)-304	2186	€ 0,37

Rapid Arc Welding	✗
Hand Welding	✓

[Order](#)



Steel

CV1

DRP

DRS

FFS

FMS

FTS

ISA

ITS

KS

SSP

SSS

STH

TV1

V2

V4

VU

CV1

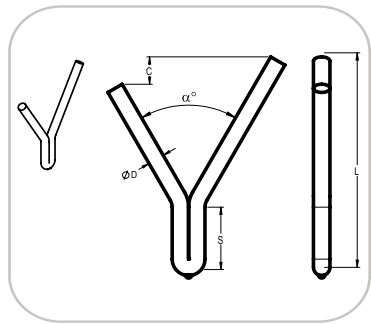

CV1.D (a)-L (c)-alloy	Pcs.	Price
CV1.6(60)-065(00)-304H	13823	€ 0,52
CV1.6(60)-040(00)-310	1439	€ 0,60

Rapid Arc Welding ✓

Hand Welding ✗

Order

DRS

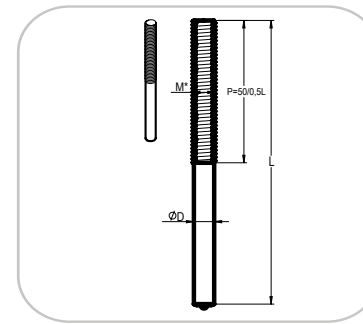

DRS.M - L - alloy	Pcs.	Price
DRS.12-205-310	1942	€ 1,93
DRS.12-150-310	2000	€ 1,58
DRS.12-100-310	1707	€ 1,23
DRS.10-040-304	4769	€ 0,73
DRS.10-025-304	1801	€ 0,74
DRS.08-040-310	2805	€ 0,75
DRS.08-025-310	2458	€ 0,73
DRS.08-020-310	5698	€ 0,72
DRS.08-018-304	7000	€ 0,67
DRS.08-025-304 RB	8933	€ 0,35
DRS.08-020-304 RB	21705	€ 0,32
DRS.08-020-304 RB	2838	€ 0,32
DRS.08-020-304 RB	1023	€ 0,32
DRS.08-018-304 RB	1586	€ 0,30

Rapid Arc Welding ✓

Hand Welding ✗

Order

DRP

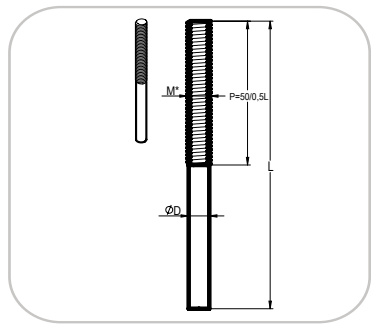

DRP.M* - L-alloy	Pcs.	Price
DRP.10-035-304	3377	€ 0,40
DRP.06-075-304	2395	€ 0,41

Rapid Arc Welding ✓

Hand Welding ✗

Order



Steel

- CV1
- DRP
- DRS
- FFS
- FMS
- FTS
- ISA
- ITS
- KS
- SSP
- SSS
- STH
- TV1
- V2
- V4
- VU

FFS

FFS.L-alloy	Pcs.	Price
FFS-100-310	2480	€ 0,61
FFS-075-601	2000	€ 0,88
FFS-065-304	1000	€ 0,55
FFS-050-601	2000	€ 0,71
FFS-050-304	1980	€ 0,51

Rapid Arc Welding

Hand Welding

Order

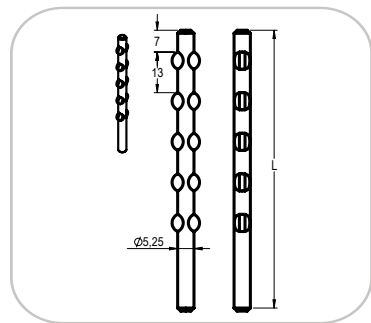

FTS

FTS.M-L(P)-alloy	Pcs.	Price
FTS.08-080/15-ST37	3335	€ 0,92

Rapid Arc Welding

Hand Welding

Order

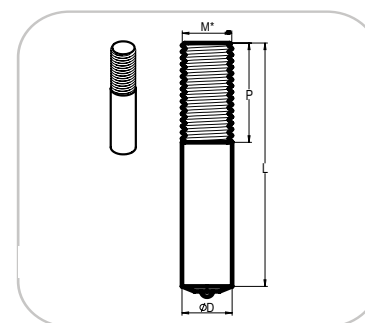

FMS

FMS.M1-L1/P1.M2-L2-alloy	Pcs.	Price
FMS.3/8"-051/038-304	4499	€ 1,60
FMS.5/16"-044/044-12-06-304	3494	€ 1,70
FMS.3/8"-051/038-12-08-304	8000	€ 1,75

Rapid Arc Welding

Hand Welding

Order

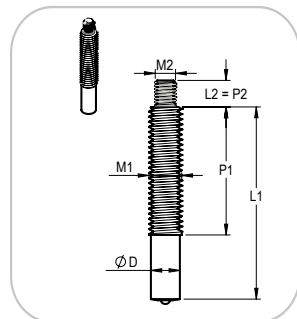

ISA

ISA.M-L-alloy	Pcs.	Price
ISA.06-030-316	9847	€ 0,85
ISA.06-030-304	2248	€ 0,75

Rapid Arc Welding

Hand Welding

Order

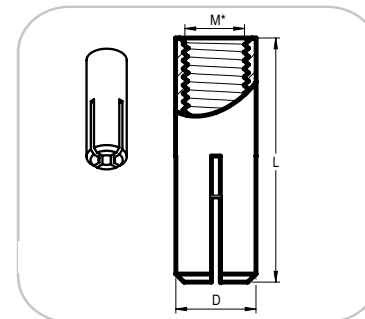



Steel

CV1

DRP

DRS

FFS

FMS

FTS

ISA

ITS

KS

SSP

SSS

STH

TV1

V2

V4

VU

ITS

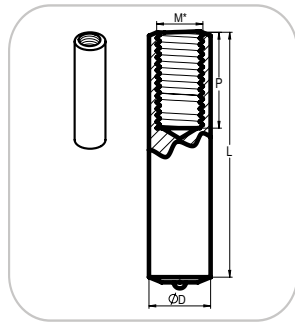

ITS.DxM*-L/P-alloy	Pcs.	Price
ITS.16XM10-025/15-ST37	2681	€ 2,07
ITS.10XM6-025/020-ST37	90100	€ 1,83
ITS.10XM6-025/020-304	56000	€ 1,90

Rapid Arc Welding	✓
Hand Welding	✗

Order

SSP

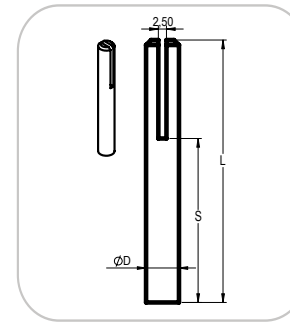

SSP.D-L(S)-alloy	Pcs.	Price
SSP.10-095-(070)-ST37 open height 90	4800	€ 1,15

Rapid Arc Welding	✗
Hand Welding	✓

Order

KS

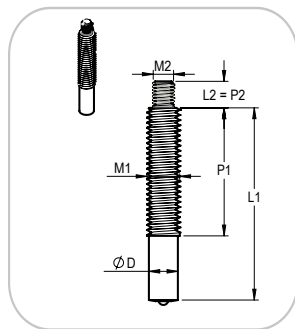

KS.D-L-alloy	Pcs.	Price
KS/BOILER Stud10x25-14742	1159	€ 0,63
Boiler Stud 10x25 -308	26675	€ 0,58
Boiler Stud 10x23-1.4828	8840	€ 0,57
BOILER STUD 10X16-14742	12800	€ 0,48
Sicromal stiften 10x20mm	4682	€ 0,53
Sicromal stiften 10x16mm	2484	€ 0,48
PENØ10X20 mm-310	2050	€ 0,26

Rapid Arc Welding	✓
Hand Welding	✗

Order

SSS

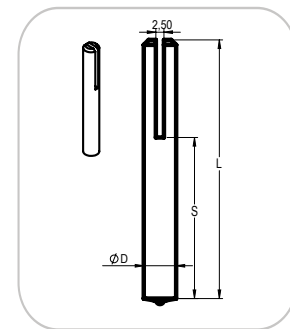

SSS.D-L(S)-alloy	Pcs.	Price
SSS.10-070(035)-310	1075	€ 1,63
SSS.10-053(025)-310	2148	€ 1,33
SSS.10-040(20)-310	4570	€ 1,13
SSS.08-067(33)-310	1978	€ 1,33

Rapid Arc Welding	✓
Hand Welding	✗

Order



Steel

CV1

DRP

DRS

FFS

FMS

FTS

ISA

ITS

KS

SSP

SSS

STH

TV1

V2

V4

VU

STH

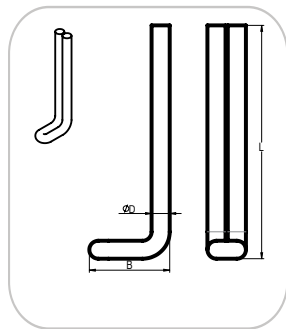

STH.D- L/B-alloy	Pcs.	Price
STH.6-189(025)-304 with 45°cuts	3290	€ 1,28

Rapid Arc Welding	✗
Hand Welding	✓

Order

V2

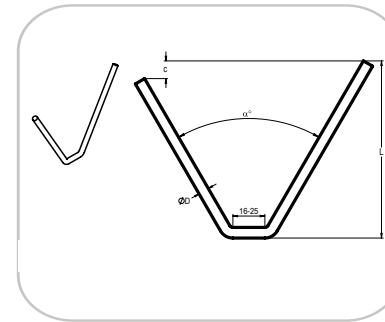

V2.D (α) - L(c)-alloy	Pcs.	Price
V2.08(60)-040(00)-304H	1000	€ 0,33

Rapid Arc Welding	✗
Hand Welding	✓

Order

TV1

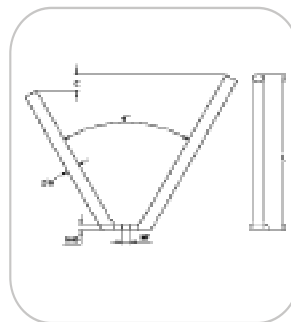

TV1.D(α) - L(c)-alloy M*	Pcs.	Price
TV1.08(60)-032(00)-310 M8	2734	€ 1,05

Rapid Arc Welding	✗
Hand Welding	✓

Order

V4

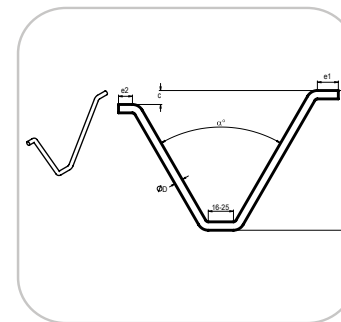

V4.D (α) - L(c)/e1.e2-alloy	Pcs.	Price
V4.06(60)-150(00)/20-20-304	4800	€ 0,51

Rapid Arc Welding	✗
Hand Welding	✓

Order



Steel

CV1

DRP

DRS

FFS

FMS

FTS

ISA

ITS

KS

SSP

SSS

STH

TV1

V2

V4

VU

VU

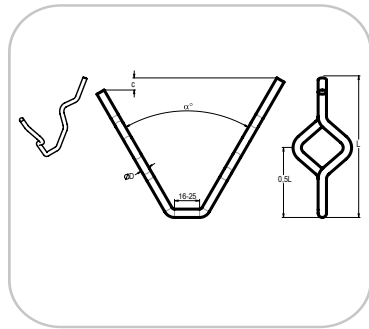

VU.D (a) - L (c) - alloy	Pcs.	Price
VU.06(60)-050(00)-304	2186	€ 0,37

Rapid Arc Welding	✗
Hand Welding	✓

[Order](#)

Incineration

CV1

CVC

FMS

FTS

ISA

ITS

KS

MPU

MTC

RIN

SHC

SSP

SSS

V2

V4

VU

CV1

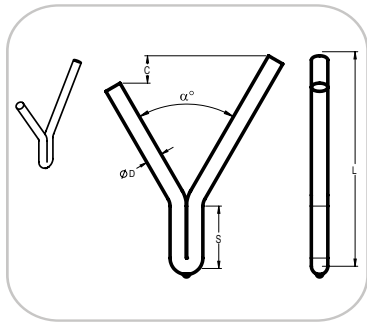

CV1.D (a)-L (c)-alloy	Pcs.	Price
CV1.6(60)-065(00)-304H	13823	€ 0,52
CV1.6(60)-040(00)-310	1439	€ 0,60

Rapid Arc Welding ✓

Hand Welding ✗

Order

FMS

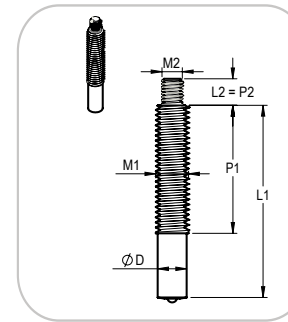

FMS.M1-L1/P1.M2-L2-alloy	Pcs.	Price
FMS.3/8"-051/038-304	4499	€ 1,60
FMS.5/16"-044/044-12-06-304	3494	€ 1,70
FMS.3/8"-051/038-12-08-304	8000	€ 1,75

Rapid Arc Welding ✓

Hand Welding ✗

Order

CVC

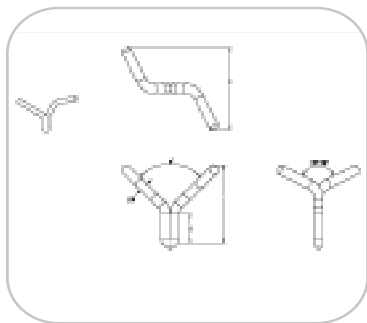

CVC.D(a) - L(s)-alloy M*	Pcs.	Price
CVC.6(90)-048(30)-309L	1678	€ 0,73

Rapid Arc Welding ✓

Hand Welding ✗

Order

FTS

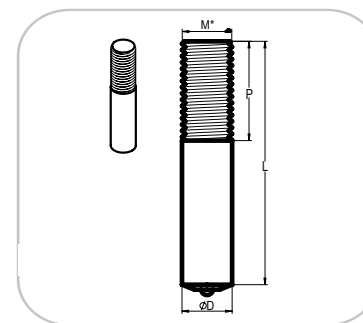

FTS.M-L(P)-alloy	Pcs.	Price
FTS.08-080/15-ST37	3335	€ 0,92

Rapid Arc Welding ✓

Hand Welding ✗

Order

Incineration

CV1

CVC

FMS

FTS

ISA

ITS

KS

MPU

MTC

RIN

SHC

SSP

SSS

V2

V4

VU

ISA

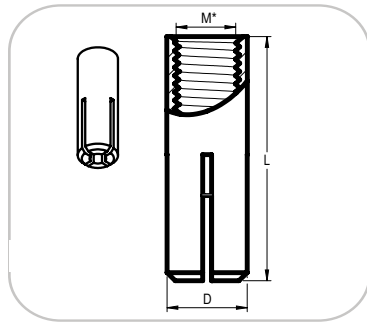

ISA.M-L-alloy	Pcs.	Price
ISA.06-030-316	9847	€ 0,85
ISA.06-030-304	2248	€ 0,75

Rapid Arc Welding ✓

Hand Welding ✗

[Order](#)

KS

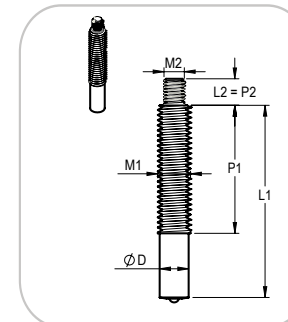

KS.D-L-alloy	Pcs.	Price
KS/BOILER Stud10x25-14742	1159	€ 0,63
Boiler Stud 10x25 -308	26675	€ 0,58
Boiler Stud 10x23-1.4828	8840	€ 0,57
BOILER STUD 10X16-14742	12800	€ 0,48
Sicromal stiften 10x20mm	4682	€ 0,53
Sicromal stiften 10x16mm	2484	€ 0,48
PENØ10X20 mm-310	2050	€ 0,26

Rapid Arc Welding ✓

Hand Welding ✗

[Order](#)

ITS

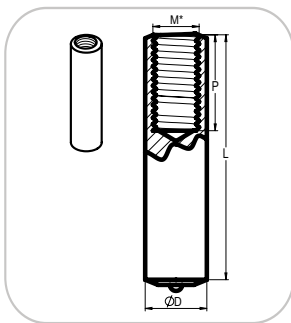

ITS.DxM*-L/P-alloy	Pcs.	Price
ITS.16XM10-025/15-ST37	2681	€ 2,07
ITS.10XM6-025/020-ST37	90100	€ 1,83
ITS.10XM6-025/020-304	56000	€ 1,90

Rapid Arc Welding ✓

Hand Welding ✗

[Order](#)

MPU

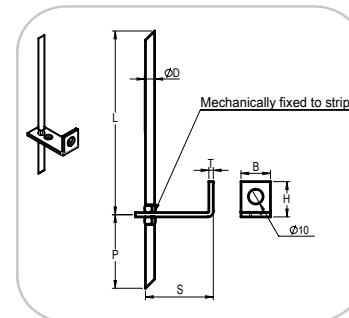

MPU.x.D.S.H(B/T)-L/P-alloy	Pcs.	Price
MPU.2.6.075.25(25/3)-250/050-304	1000	€ 1,25

Rapid Arc Welding ✗

Hand Welding ✓

[Order](#)



Incineration

CV1

CVC

FMS

FTS

ISA

ITS

KS

MPU

MTC

RIN

SHC

SSP

SSS

V2

V4

VU

MTC

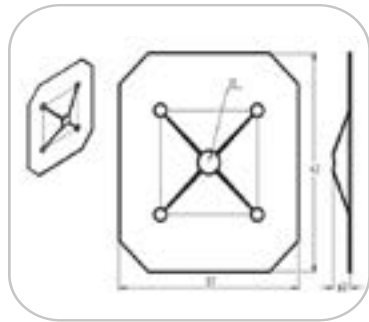

MTC-R-alloy	Pcs.	Price
MTC-104-301	1026	€ 0,45

Rapid Arc Welding	✗
Hand Welding	✗

Order

SHC

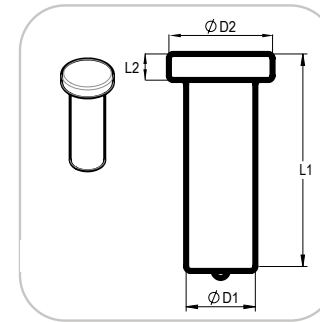

SHC.22-200-ST37	Pcs.	Price
SHC.22-200-ST37	1300	€ 1,45

Rapid Arc Welding	✓
Hand Welding	✗

Order

RIN

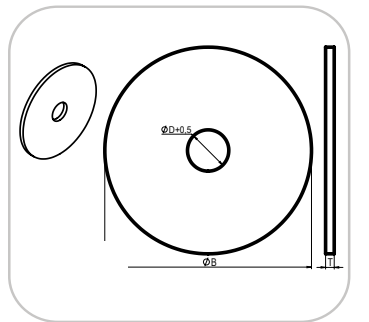

RIN.B - D(T) - alloy	Pcs.	Price
Rin.080-016(2.0)-314	2800	€ 0,80
RIN.060-008(1.5)-321	2975	€ 0,50
RIN.040-014(2.0)-310	5060	€ 0,38
RIN.040-012(2.0)-310	1460	€ 0,37
RIN.038-006(1.5)-310	40090	€ 0,33
RIN.020-010(3.0)-310	1023	€ 0,30

Rapid Arc Welding	✗
Hand Welding	✗

Order

SSP

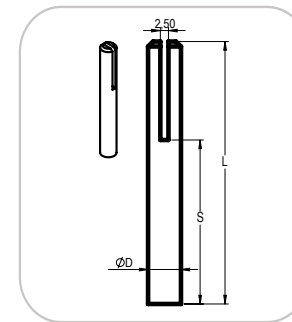

SSP.D-L(S)-alloy	Pcs.	Price
SSP.10-095-(070)-ST37 open height 90	4800	€ 1,15

Rapid Arc Welding	✗
Hand Welding	✓

Order

Incineration

CV1

CVC

FMS

FTS

ISA

ITS

KS

MPU

MTC

RIN

SHC

SSP

SSS

V2

V4

VU

SSS

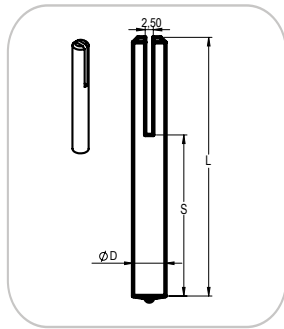

SSS.D-L(S)-alloy	Pcs.	Price
SSS.10-070(035)-310	1075	€ 1,63
SSS.10-053(025)-310	2148	€ 1,33
SSS.10-040(20)-310	4570	€ 1,13
SSS.08-067(33)-310	1978	€ 1,33

Rapid Arc Welding	✓
Hand Welding	✗

Order

V4

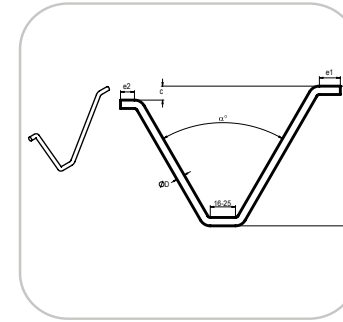

V4.D (a) - L(c)/e1.e2-alloy	Pcs.	Price
V4.06(60)-150(00)/20-20-304	4800	€ 0,51

Rapid Arc Welding	✗
Hand Welding	✓

Order

V2

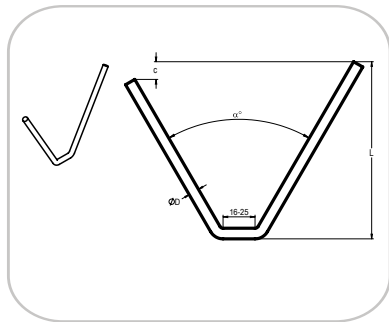

V2.D (a) - L(c)-alloy	Pcs.	Price
V2.08(60)-040(00)-304H	1000	€ 0,33

Rapid Arc Welding	✗
Hand Welding	✓

Order

VU

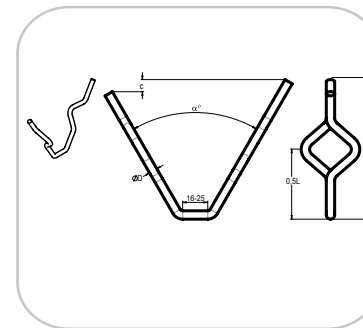

VU.D (a) - L (c) - alloy	Pcs.	Price
VU.06(60)-050(00)-304	2186	€ 0,37

Rapid Arc Welding	✗
Hand Welding	✓

Order

Power

DRP

DRS

FFS

IPH

MPU

DRP

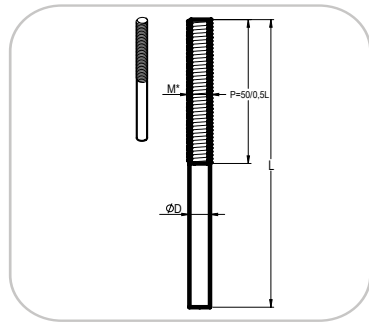

DRP.M* - L-alloy	Pcs.	Price
DRP.10-035-304	3377	€ 0,40
DRP.06-075-304	2395	€ 0,41

Rapid Arc Welding	✓
Hand Welding	✗

Order

DRS

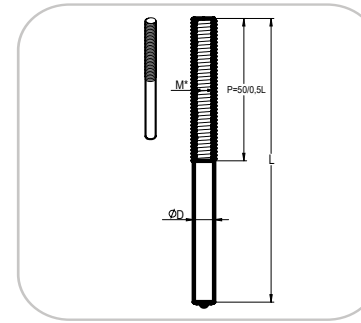

DRS.M - L - alloy	Pcs.	Price
DRS.12-205-310	1942	€ 1,93
DRS.12-150-310	2000	€ 1,58
DRS.12-100-310	1707	€ 1,23
DRS.10-040-304	4769	€ 0,73
DRS.10-025-304	1801	€ 0,74
DRS.08-040-310	2805	€ 0,75
DRS.08-025-310	2458	€ 0,73
DRS.08-020-310	5698	€ 0,72
DRS.08-018-304	7000	€ 0,67
DRS.08-025-304 RB	8933	€ 0,35
DRS.08-020-304 RB	21705	€ 0,32
DRS.08-020-304 RB	2838	€ 0,32
DRS.08-020-304 RB	1023	€ 0,32
DRS.08-018-304 RB	1586	€ 0,30

Rapid Arc Welding	✓
Hand Welding	✗

Order

FFS

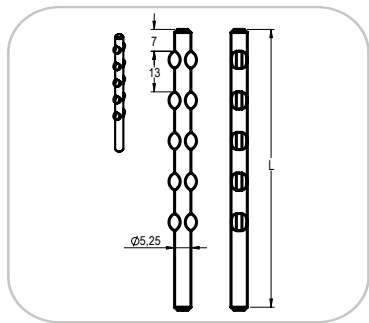

FFS.L-alloy	Pcs.	Price
FFS-100-310	2480	€ 0,61
FFS-075-601	2000	€ 0,88
FFS-065-304	1000	€ 0,55
FFS-050-601	2000	€ 0,71
FFS-050-304	1980	€ 0,51

Rapid Arc Welding	✓
Hand Welding	✗

Order

Power

DRP

DRS

FFS

IPH

MPU

IPH

IPH.D-L(H)-alloy	Pcs.	Price
IPH.10-225(16)-308	1623	€ 1,25

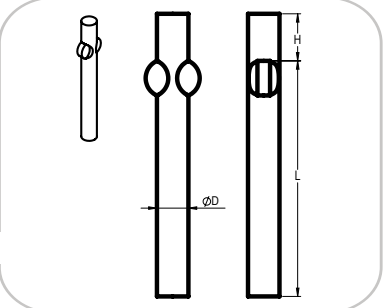

Rapid Arc Welding	✗
Hand Welding	✓

[Order](#)

MPU

MPU.x.D.S.H(B/T)-L/P-alloy	Pcs.	Price
MPU.2.6.075.25(25/3)- 250/050-304	1000	€ 1,25

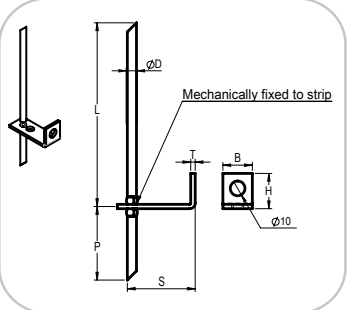

Rapid Arc Welding	✗
Hand Welding	✓

[Order](#)



Shipbuilding

FMS

FTS

ISA

ITS

SHC

FMS

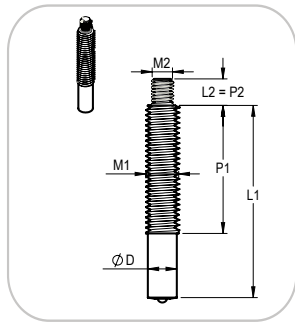

FMS.M1-L1/P1.M2-L2-alloy	Pcs.	Price
FMS.3/8"-051/038-304	4499	€ 1,60
FMS.5/16"-044/044-12-06-304	3494	€ 1,70
FMS.3/8"-051/038-12-08-304	8000	€ 1,75

Rapid Arc Welding	✓
Hand Welding	✗

Order

ISA

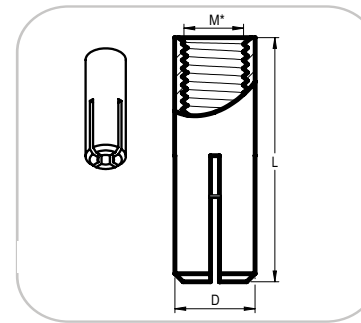

ISA.M-L-alloy	Pcs.	Price
ISA.06-030-316	9847	€ 0,85
ISA.06-030-304	2248	€ 0,75

Rapid Arc Welding	✓
Hand Welding	✗

Order

FTS

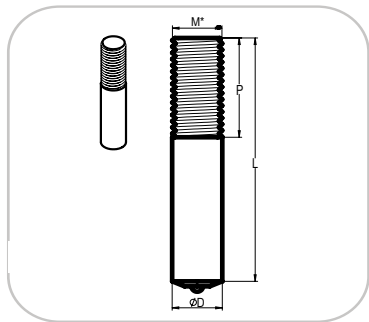

FTS.M-L(P)-alloy	Pcs.	Price
FTS.08-080/15-ST37	3335	€ 0,92

Rapid Arc Welding	✓
Hand Welding	✗

Order

ITS

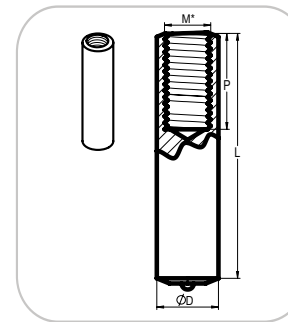

ITS.DxM*-L/P-alloy	Pcs.	Price
ITS.16XM10-025/15-ST37	2681	€ 2,07
ITS.10XM6-025/020-ST37	90100	€ 1,83
ITS.10XM6-025/020-304	56000	€ 1,90

Rapid Arc Welding	✓
Hand Welding	✗

Order



Shipbuilding

FMS

FTS

ISA

ITS

SHC

SHC

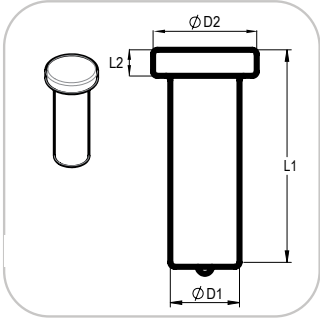
	SHC.22-200-ST37	Pcs.	Price
	SHC.22-200-ST37	1300	€ 1,45
			Rapid Arc Welding ✓
			Hand Welding ✗
			Order

Didn't find your anchor?

Contact our Sales team for **your offer!**

Getting in touch with our sales people is a simple matter. Just look for the person who deals with your specific country and/or language. Feel free to call himher directly and explain your requirements.



Looking for welding services?

Discover our cost-saving **Rapid Arc Welding!**

Rapid Arc Welding (RAW) is an innovative method of fixing refractory anchors inside high temperature vessels and furnaces, it is recognized industry-wide for its ability to optimize the quality, speed and safety of the anchor installation process.

SILICON Headquarters
The Netherlands
T +31 (0) 174-225522
info@silicon.nu

SILICON Rapid Arc Welding C&S
USA
T +(832) 762 5066
info@silicon-usa.com

SILICON Asia
Japan
T +81 70 8383 9253
info@silicon-asia.com